

TS2GSDM80

2GB miniSD Memory Card

Description

miniSD Card is a compact, slim and high capacity storage media with copyright protection. Designed in advanced SD specification Ver.1.1, TS2GSDM80 now reaches a new performance milestone. Based on 0.18um process controller and high quality SLC (Single-Level-Cell) NAND Flash chip, TS2GSDM80 can provide high performance ,low power consumption yet excellent reliability.

Placement



Front

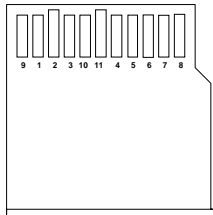

Back

Features

- Storage Capacity: 2GB(2GX8bit,2KB/page)
- Operating Voltage: 2.7 ~ 3.6V
- Operating Temperature: -25 ~ 85°C
- Maximum Data Transfer Rate:
Read:12MB/sec,Write:11MB/sec
- Insertion/removal durability: 10,000 cycles
- Fully compatible with SD card spec. v1.1
- Forward compatibility to MultiMediaCard Version 2.11
- Supports Copy Protection for Recorded Media(CPRM) for music and other commercial media
- Form Factor: 21.5mm x 20mm x 1.4mm

Pin Definition

Pin No.	Name	Type	Description
1	CD/DAT3	I/O/PP ³	Card Detect/Data Line [Bit3]
2	CMD	PP	Command/Response
3	V _{SS1}	S	Supply voltage ground
4	V _{DD}	S	Supply voltage
5	CLK	I	Clock
6	V _{SS2}	S	Supply voltage ground
7	DAT0	I/O/PP	Data Line [Bit0]
8	DAT1	I/O/PP	Data Line [Bit1]
9	DAT2	I/O/PP	Data Line [Bit2]
10	NC ⁴	I/O/PP	For Future Use
11	NC ⁴	I/O/PP	For Future Use

Architecture

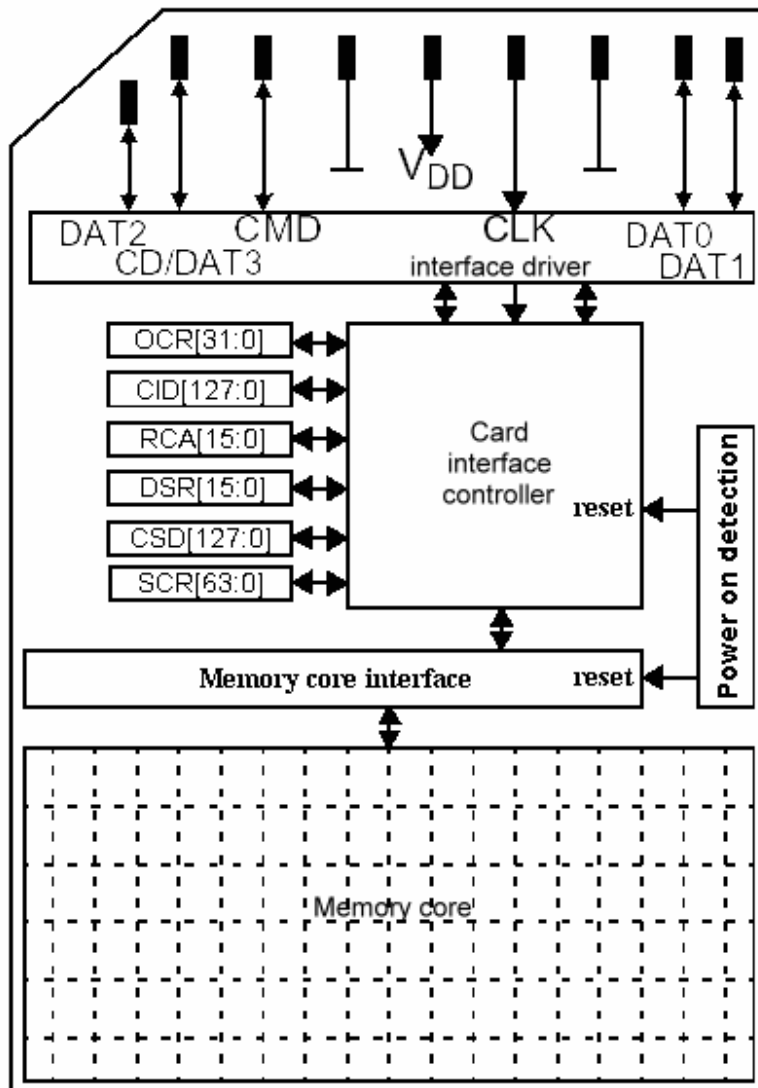

Bus Operating Conditions

• General

Parameter	Symbol	Min.	Max.	Unit	Remark
Peak voltage on all lines		-0.3	VDD+0.3	V	
All Inputs					
Input Leakage Current		-10	10	μA	
All Outputs					
Output Leakage Current		-10	10	μA	

• Power Supply Voltage

Parameter	Symbol	Min.	Max.	Unit	Remark
Supply voltage	V _{DD}	2.0	3.6	V	CMD0, 15,55,ACMD41 commands
Supply voltage specified in OCR register		2.7	3.6	V	Except CMD0, 15,55, ACMD41 commands
Supply voltage differentials (V _{SS1} , V _{SS2})		-0.3	0.3	V	
Power up time			250	ms	From 0v to V _{DD} Min.

Note. The current consumption of any card during the power-up procedure must not exceed 10 mA.

• Bus Signal Line Load

The total capacitance C_L the CLK line of the SD Memory Card bus is the sum of the bus master capacitance C_{HOST}, the bus capacitance C_{BUS} itself and the capacitance C_{CARD} of each card connected to this line:

$$C_L = C_{HOST} + C_{BUS} + N \cdot C_{CARD}$$

Where N is the number of connected cards. Requiring the sum of the host and bus capacitances not to exceed 30 pF for up to 10 cards, and 40 pF for up to 30 cards, the following values must not be exceeded:

Parameter	Symbol	Min.	Max.	Unit	Remark
Bus signal line capacitance	C _L		100	pF	f _{PP} ≤ 20 MHz, 7 cards
Single card capacitance	C _{CARD}		10	pF	
Maximum signal line inductance			16	nH	f _{PP} ≤ 20 MHz
Pull-up resistance inside card (pin1)	R _{DAT3}	10	90	kΩ	May be used for card detection

Note that the total capacitance of CMD and DAT lines will be consist of C_{HOST}, C_{BUS} and one C_{CARD} only since they are connected separately to the SD Memory Card host.

Parameter	Symbol	Min.	Max.	Unit	Remark
Pull-up resistance	R _{CMD} , R _{DAT}	10	100	kΩ	To prevent bus floating
Bus signal line capacitance	C _L		250	pF	f _{PP} ≤ 5 MHz, 21 cards

• Bus Signal Levels

As the bus can be supplied with a variable supply voltage, all signal levels are related to the supply voltage.

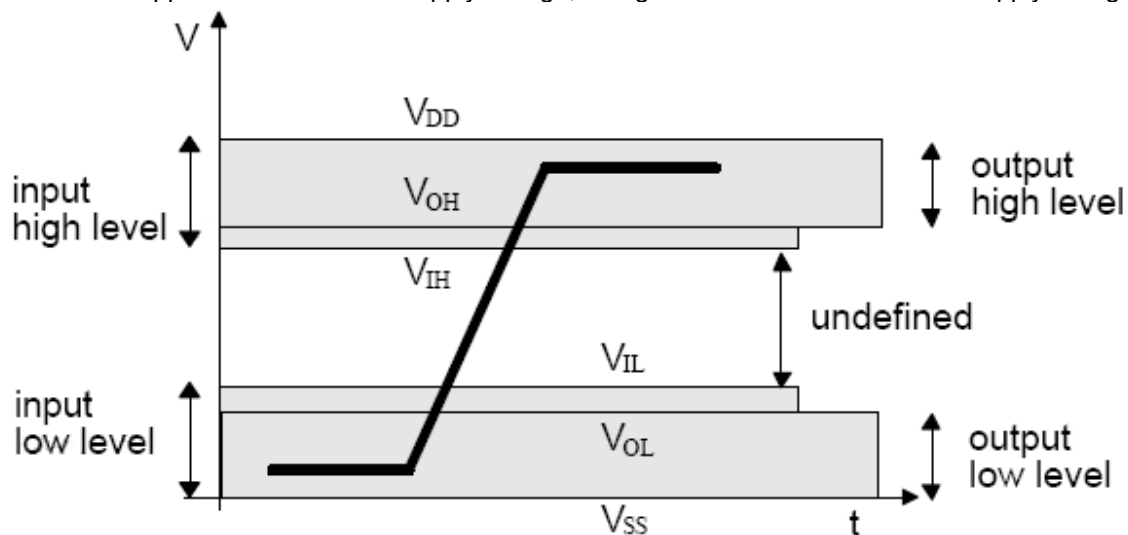

To meet the requirements of the JEDEC specification JESD8-1A, the card input and output voltages shall be within the following specified ranges for any V_{DD} of the allowed voltage range:

Parameter	Symbol	Min.	Max.	Unit	Remark
Output HIGH voltage	V_{OH}	$0.75 * V_{DD}$		V	$I_{OH} = -100 \mu A @ V_{DD} \text{ min}$
Output LOW voltage	V_{OL}		$0.125 * V_{DD}$	V	$I_{OL} = -100 \mu A @ V_{DD} \text{ min}$
Input HIGH voltage	V_{IH}	$0.625 * V_{DD}$	$V_{DD} + 0.3$	V	
Input LOW voltage	V_{IL}	$V_{SS} - 0.3$	$0.25 * V_{DD}$	V	

• Bus Timing (Default)

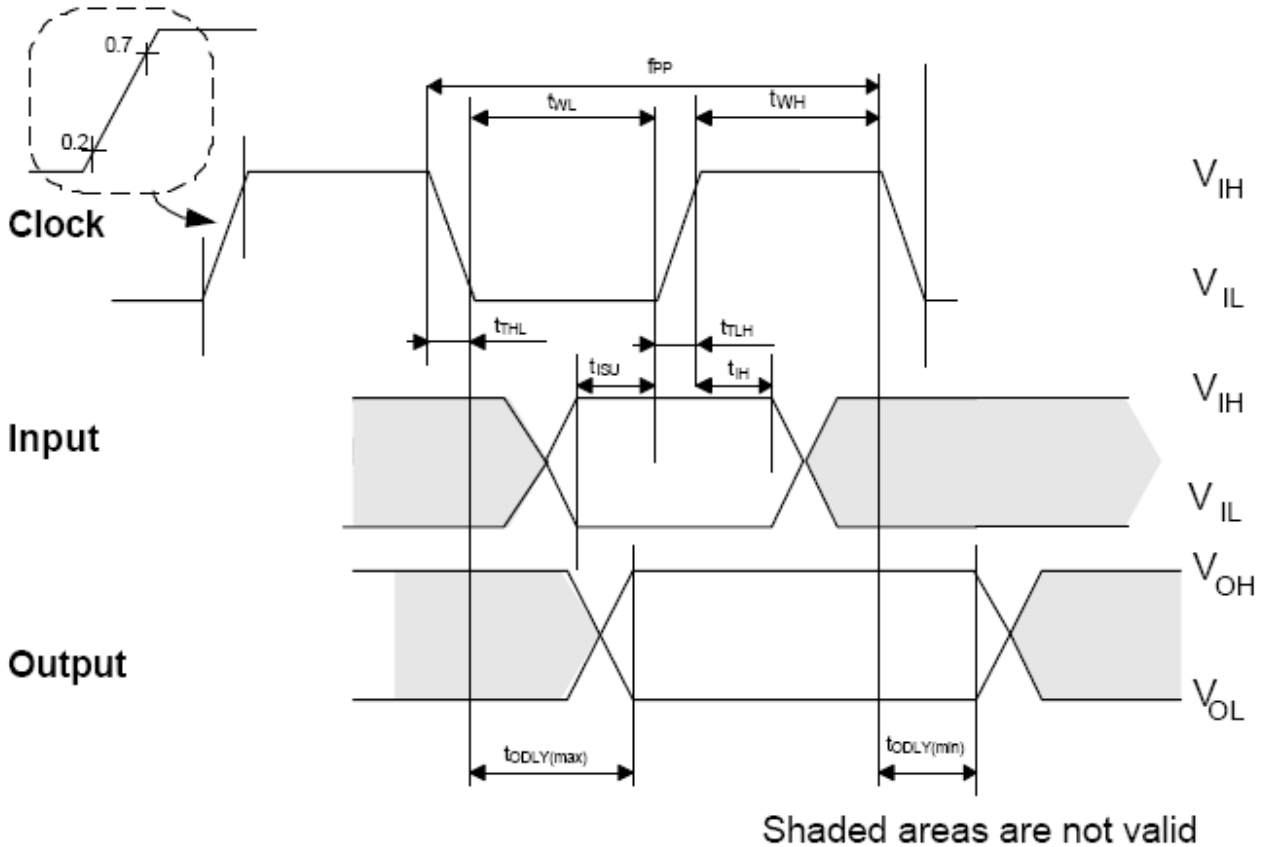

Figure 47: Timing diagram data input/output referenced to clock (Default)

Parameter	Symbol	Min	Max.	Unit	Remark
Clock CLK (All values are referred to min (V_{IH}) and max (V_{IL}))					
Clock frequency Data Transfer Mode	f_{PP}	0	25	MHz	$C_L \leq 100$ pF, (7 cards)
Clock frequency Identification Mode (The low freq. is required for MultiMediaCard compatibility.)	f_{OD}	0	400	KHz	$C_L \leq 250$ pF, (21 cards)
Clock low time	t_{WL}	10		ns	$C_L \leq 100$ pF, (7 cards)
		50		ns	$C_L \leq 250$ pF, (21 cards)
Clock high time	t_{WH}	10		ns	$C_L \leq 100$ pF, (7 cards)
		50		ns	$C_L \leq 250$ pF, (21 cards)
Clock rise time	t_{TLH}		10	ns	$C_L \leq 100$ pF, (7 cards)

TS2GSDM80

2GB miniSD Memory Card

			50	ns	$C_L \leq 250$ pF, (21 cards)
Clock fall time	t_{THL}		10	ns	$C_L \leq 100$ pF, (7 cards)
			50	ns	$C_L \leq 250$ pF, (21 cards)
Inputs CMD, DAT (referenced to CLK)					
Input set-up time	t_{ISU}	5		ns	$C_L \leq 25$ pF, (1 cards)
Input hold time	t_{IH}	5		ns	$C_L \leq 25$ pF, (1 cards)
Outputs CMD, DAT (referenced to CLK)					
Output Delay time during Data Transfer Mode	t_{ODLY}	0	14	ns	$C_L \leq 25$ pF, (1 cards)
Output Delay time during Identification Mode	t_{ODLY}	0	50	ns	$C_L \leq 25$ pF, (1 cards)

• Bus Timing (High Speed Mode)

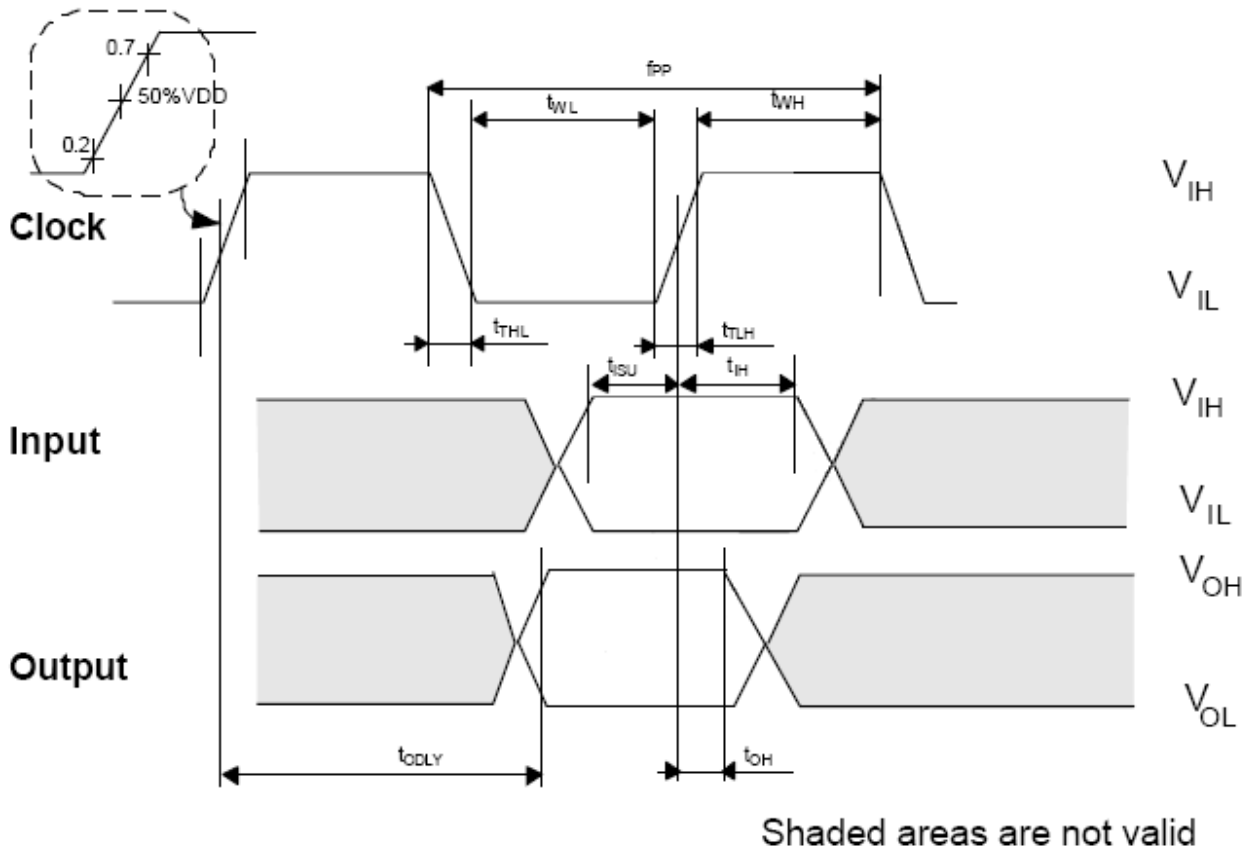

Figure 48: Timing diagram data input/output referenced to clock (High-Speed)

Parameter	Symbol	Min	Max.	Unit	Remark
Clock CLK (All values are referred to min (V_{IH}) and max (V_{IL}))					
Clock frequency Data Transfer Mode	f_{PP}	0	50	MHz	
Clock low time	t_{WL}	7		ns	
Clock high time	t_{WH}	7		ns	
Clock rise time	t_{TLH}		3	ns	
Clock fall time	t_{THL}		3	ns	
Inputs CMD, DAT (referenced to CLK)					
Input set-up time	t_{ISU}	6		ns	
Input hold time	t_{IH}	2		ns	
Outputs CMD, DAT (referenced to CLK)					

TS2GSDM80

2GB miniSD Memory Card

Output Delay time during Data Transfer Mode	t_{ODLY}		14	ns	
Output Hold time	t_{OH}	2.5		ns	
Total System capacitance for each line	C_L		40	pF	

Reliability and Durability

Temperature	Operation: -25°C / 85°C (Target spec) Storage: -40°C (168h) / 85°C (500h) Junction temperature: max. 95°C
Moisture and corrosion	Operation: 25°C / 95% rel. humidity Storage: 40°C / 93% rel. hum./500h Salt Water Spray: 3% NaCl/35C; 24h acc. MIL STD Method 1009
Durability	10.000 mating cycles;
Bending	10N
Torque	0.15N.m or +/-2.5 deg
Drop test	1.5m free fall
UV light exposure	UV: 254nm, 15Ws/cm ² according to ISO 7816-1
Visual inspection Shape and form	No warp page; no mold skin; complete form; no cavities surface smoothness <= -0.1 mm/cm ² within contour; no cracks; no pollution (fat, oil dust, etc.)

Above technical information is based on industry standard data and tested to be reliable. However, Transcend makes no warranty, either expressed or implied, as to its accuracy and assumes no liability in connection with the use of this product. Transcend reserves the right to make changes in specifications at any time without prior notice.