

# TS128MRMMC4

128MB MMCmobile

## Description

TS128MRMMC4 is a 128MB MMCmobile memory card. It's a fastest, low-power, highly integration memory card. TS128MRMMC4 is designed to provide an inexpensive, mechanically robust storage medium in card form for multimedia consumer applications and mobile devices (handheld PCs, digital cameras, MP3 players, etc.) to store, copy, and move data at high-speed transfer rate.

## Placement



Front

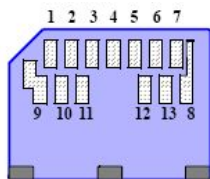

Back

## Features

- Storage Capacity: 128MB
- Support Dual Operating Voltage: 2.7~3.6V/1.65~1.95V
- Support clock frequencies: 0~52MHz
- Support different Bus width: x1, x4, x8
- Operating Temperature: -25°C ~ 85°C
- Storage Temperature: -40°C ~ 85°C
- Data access mode: Byte mode
- Data Transfer Rate (Maximum):  
Read:9MB/sec,Write:8MB/sec
- Fully compatible with MultiMediaCard system specification version 4.0 and backwards compatibility with previous specification
- Form Factor: 18mm x 24mm x 1.4mm

## Pin Definition

Pin No.	MMC Mode			SPI Mode		
	Name	Type	Description	Name	Type	Description
1	DAT3	I/O/PP	Data	CS	I	Chip select
2	CMD	I/O/PP/OD	Command/Response	DI	I/PP	Data in
3	VSS1	S	Ground	VSS	S	Ground
4	VDD	S	Power supply	VDD	S	Power supply
5	CLK	I	Clock	SCLK	I	Clock
6	VSS2	S	Ground	VSS2	S	Ground
7	DAT0	I/O/PP	Data	DO	O/PP	Data out
8	DAT1	I/O/PP	Data	Not used		
9	DAT2	I/O/PP	Data	Not used		
10	DAT4	I/O/PP	Data	Not used		
11	DAT5	I/O/PP	Data	Not used		
12	DAT6	I/O/PP	Data	Not used		
13	DAT7	I/O/PP	Data	Not used		

S: Power Supply; I:Input; O:Output; PP:Push-Pull; OD:Open-Drain; NC:Not Connected

## MultiMediaCard Architecture

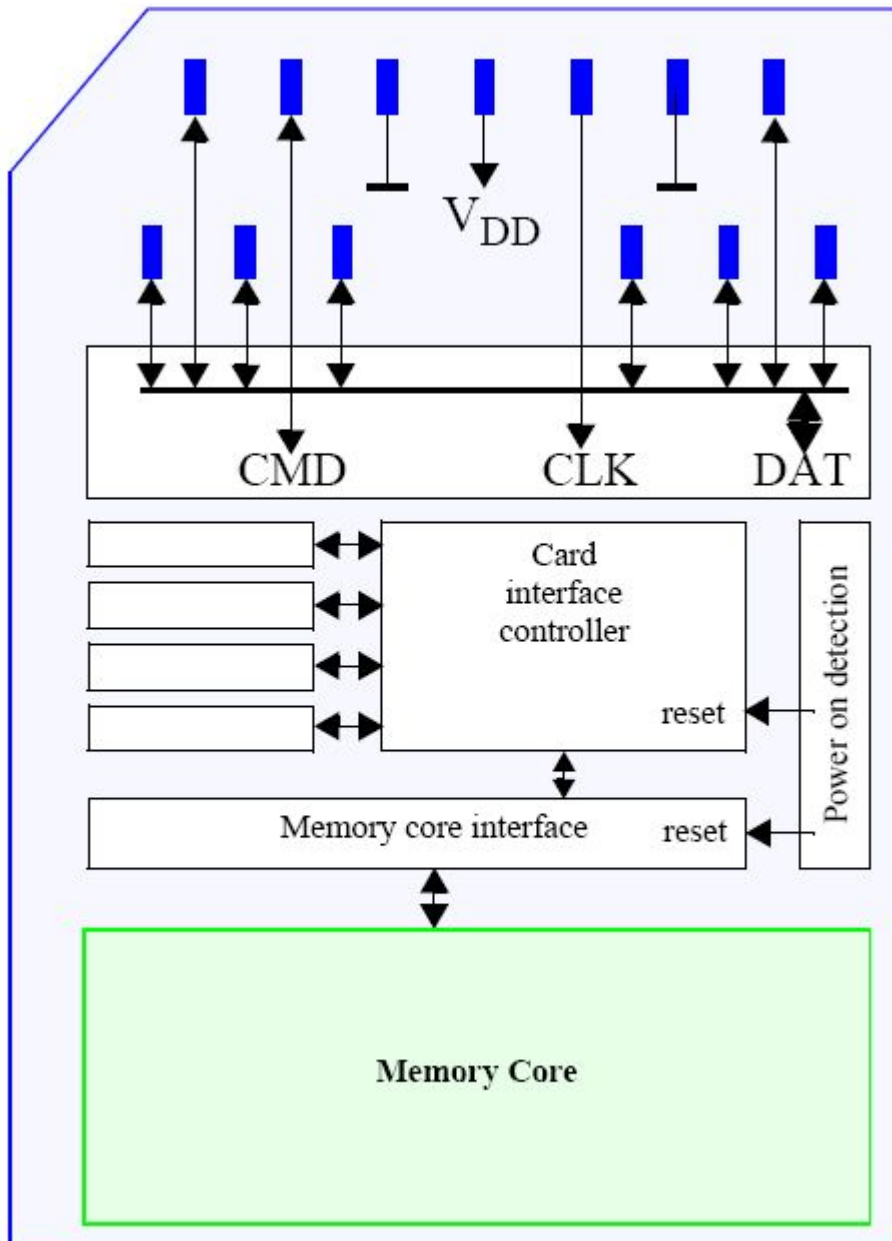

## Temperature Characteristics

Parameter	Min.	Max.	Unit
Operating temperature	-25	85	°C
Storage temperature	-40	85	°C
Junction temperature		95	°C

## Electrical Characteristics

### • Absolute Maximum Ratings

Parameter	Symbol	Rating	Unit
Power Supply Voltage	$V_{CC}$	-0.6~+4.6	V
Input Voltage	$V_{IN}$	-0.6~+4.6	V
Input/Output Voltage	$V_{I/O}$	-0.6~+4.6	V

### • Recommended Operation Conditions

Parameter	Symbol	Min.	Typ.	Max.	Unit
Power Supply Voltage (High Voltage Range)	$V_{DDH}$	2.7	3.3	3.6	V
Power Supply Voltage (Low Voltage Range)	$V_{DDL}$	1.65	1.8	1.95	V

## DC Characteristics

### • High Voltage Power Supply

(Ta=-25°C to 85°C, V<sub>DDH</sub>=2.7V to 3.6V)

Parameter	Symbol	Min.	Typ.	Max.	Unit	Condition
Output Low Voltage (OD)	V <sub>ODOL</sub>			0.3	V	I <sub>OL</sub> =2mA
Output High Voltage (PP)	V <sub>OH</sub>	0.75* V <sub>DDH</sub>			V	I <sub>OH</sub> =-100uA
Output Low Voltage (PP)	V <sub>OL</sub>			0.125* V <sub>DDH</sub>	V	I <sub>OL</sub> =100uA
Input High Voltage	V <sub>IH</sub>	0.625* V <sub>DDH</sub>		V <sub>DDH</sub> +0.3	V	
Input Low Voltage	V <sub>IL</sub>	-0.3		0.25* V <sub>DDH</sub>	V	
Operating Current	I <sub>CC</sub>			20(TBD)	mA	I <sub>VCCF</sub> =0mA
Stand-by Current	I <sub>SB</sub>			400(TBD)	uA	
Input Leakage Current	I <sub>LI</sub>			-10/+10	uA	V <sub>IN</sub> =0 to V <sub>DDH</sub>
Output Leakage Current	I <sub>LO</sub>			-10/+10	uA	V <sub>OUT</sub> =0 to V <sub>DDH</sub>
Pin Capacitance	C <sub>P</sub>			7	pF	
Power Output Voltage	V <sub>F</sub>	1.50	1.8	1.95	V	I <sub>F</sub> <= 240mA

### • Low Voltage Power Supply

(Ta=-25°C to 85°C, V<sub>DDL</sub>=1.65V to 1.95V)

Parameter	Symbol	Min.	Typ.	Max.	Unit	Condition
Output High Voltage	V <sub>OH</sub>	V <sub>DDL</sub> -0.2			V	I <sub>OH</sub> =-100uA
Output Low Voltage	V <sub>OL</sub>			0.2	V	I <sub>OL</sub> =100uA
Input High Voltage	V <sub>IH</sub>	0.7* V <sub>DDL</sub>		V <sub>DDL</sub> +0.3	V	
Input Low Voltage	V <sub>IL</sub>	-0.3		0.3* V <sub>DDL</sub>	V	
Operating Current	I <sub>CC</sub>			20(TBD)	mA	I <sub>VCCF</sub> =0mA
Stand-by Current	I <sub>SB</sub>			400(TBD)	uA	
Input Leakage Current	I <sub>LI</sub>			-10/+10	uA	V <sub>IN</sub> =0 to V <sub>DDL</sub>
Output Leakage Current	I <sub>LO</sub>			-10/+10	uA	V <sub>OUT</sub> =0 to V <sub>DDL</sub>
Pin Capacitance	C <sub>P</sub>			7	pF	

## AC Characteristics

### • High Speed Card Interface Timing

( $T_a = -25^{\circ}\text{C}$  to  $85^{\circ}\text{C}$ ,  $V_{DDH} = 2.7\text{V}$  to  $3.6\text{V}$ )

Parameter	Symbol	Min.	Max.	Unit	Notes
Clock Frequency (Data Transfer Mode)	$f_{pp}$	26	52	MHz	
Clock Frequency (Identification Mode)	$f_{OD}$	0	400	KHz	
Clock Low Time	$t_{WL}$	6.5		ns	
Clock Rise Time	$t_{TLH}$		3	ns	
Clock Fall Time	$t_{THL}$		3	ns	
Input Set-up Time	$t_{ISU}$	3		ns	
Input Hold Time	$t_{IH}$	3		ns	
Output Delay Time	$t_{DLY}$	5	14	ns	$C_L \leq 30\text{pF}$
Signal Rise Time	$t_{rise}$		3	ns	$C_L \leq 30\text{pF}$
Signal Fall Time	$t_{fall}$		3	ns	$C_L \leq 30\text{pF}$

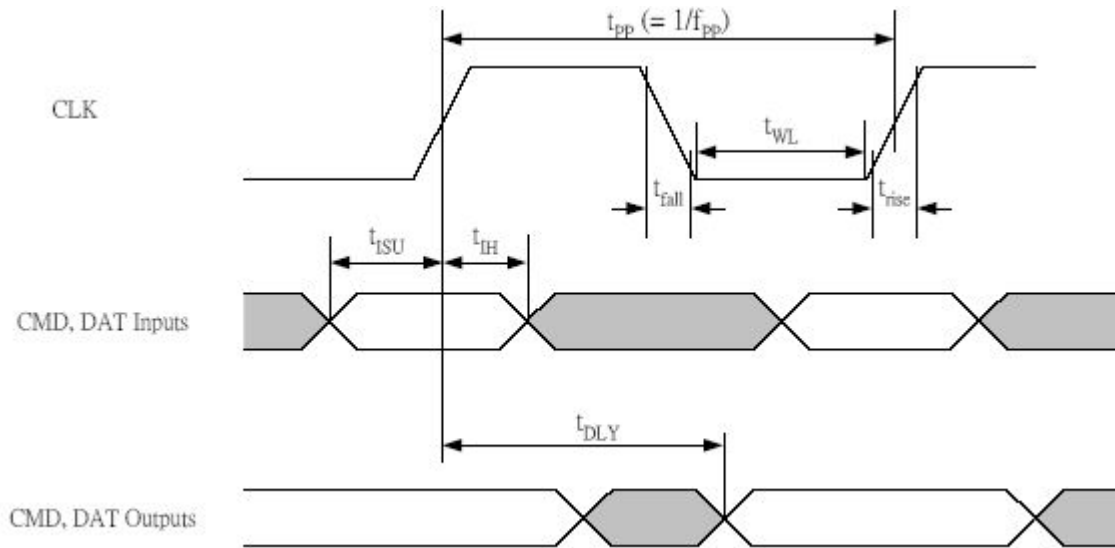

• Backwards Compatible Card Interface Timing

( $T_a = -25^{\circ}\text{C}$  to  $85^{\circ}\text{C}$ ,  $V_{DDH} = 2.7\text{V}$  to  $3.6\text{V}$ )

Parameter	Symbol	Min.	Max.	Unit	Notes
Clock Frequency (Data Transfer Mode)	$f_{pp}$	0	20	MHz	
Clock Frequency (Identification Mode)	$f_{OD}$	0	400	KHz	
Clock Low Time	$t_{WL}$	10		ns	
Clock Rise Time	$t_{TLH}$		10	ns	
Clock Fall Time	$t_{THL}$		10	ns	
Input Set-up Time	$t_{ISU}$	3		ns	
Input Hold Time	$t_{IH}$	3		ns	
Output Delay Time	$t_{DLY}$	9.7	35	ns	$C_L \leq 30\text{pF}$

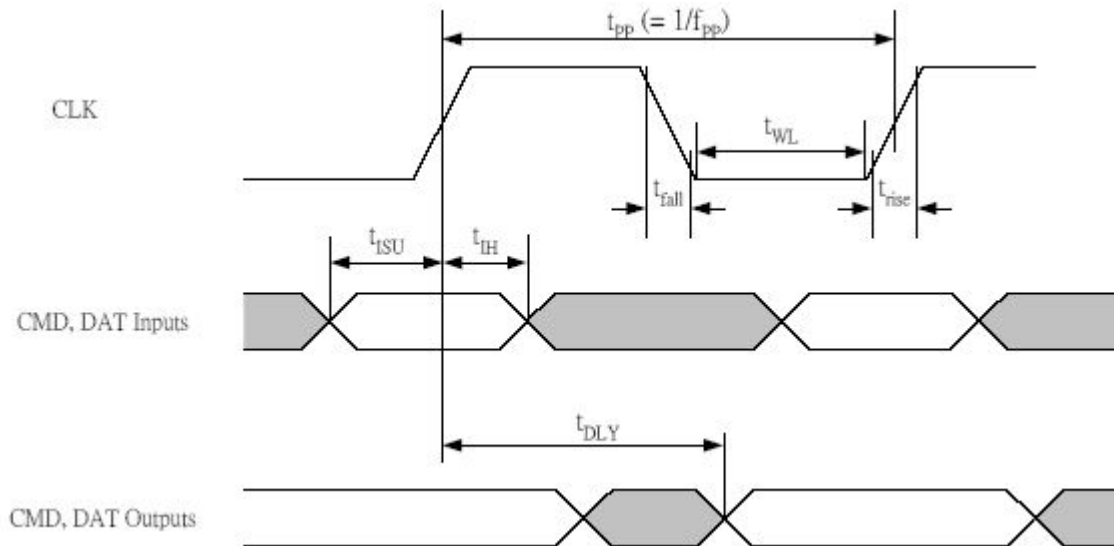

• Command Latch Cycle

Parameter	Symbol	Min.	Unit	Notes
CLE Setup Time	$t_{CLS1}$	30	ns	$C_L \leq 80\text{pF}$
CLE Hold Time	$t_{CLH1}$	15	ns	$C_L \leq 80\text{pF}$
CE Setup Time	$t_{CS1}$	40	ns	$C_L \leq 80\text{pF}$
CE Hold Time	$t_{CH1}$	90	ns	$C_L \leq 80\text{pF}$
ALE Setup Time	$t_{ALS1}$	90	ns	$C_L \leq 80\text{pF}$
ALE Hold Time	$t_{ALH1}$	75	ns	$C_L \leq 80\text{pF}$
WE Pulse Width	$t_{WP1}$	45	ns	$C_L \leq 80\text{pF}$
Data Setup Time	$t_{DS1}$	90	ns	$C_L \leq 80\text{pF}$
Data Hold Time	$t_{DH1}$	30	ns	$C_L \leq 80\text{pF}$

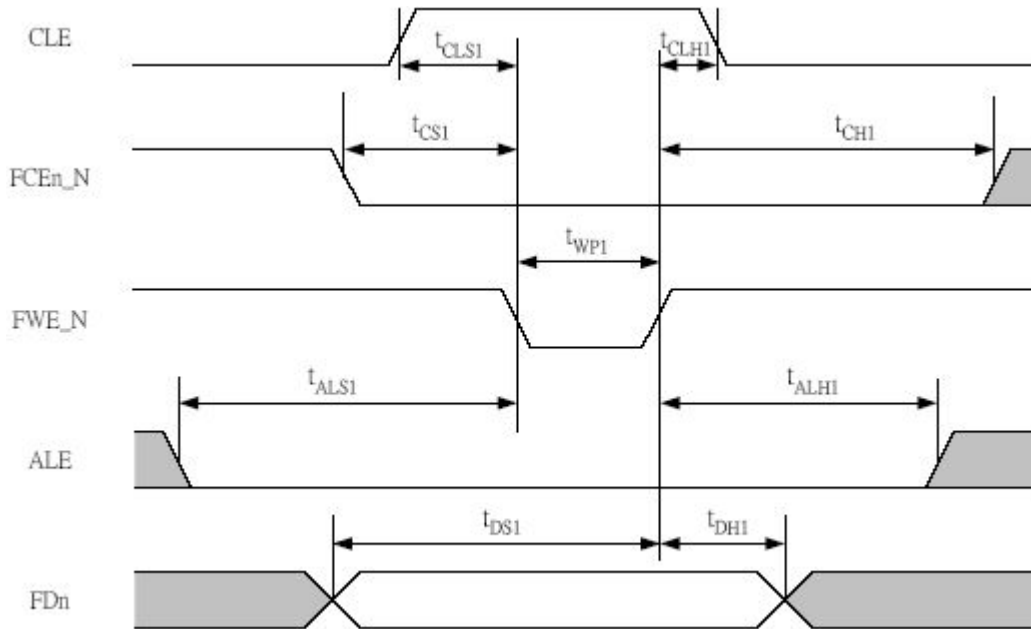

• Address Latch Cycle

Parameter	Symbol	Min.	Unit	Remark
CLE Setup Time	$t_{CLS2}$	90	ns	$C_L \leq 80\text{pF}$
CE Setup Time	$t_{CS2}$	195	ns	$C_L \leq 80\text{pF}$
ALE Setup Time	$t_{ALS2}$	30	ns	$C_L \leq 80\text{pF}$
ALE Hold Time	$t_{ALH2}$	15	ns	$C_L \leq 80\text{pF}$
Write Cycle Time	$t_{WC2}$	150	ns	$C_L \leq 80\text{pF}$
WE Pulse Width	$t_{WP2}$	45	ns	$C_L \leq 80\text{pF}$
WE High Hold Time	$t_{WH2}$	105	ns	$C_L \leq 80\text{pF}$
Data Setup Time	$t_{DS2}$	90	ns	$C_L \leq 80\text{pF}$
Data Hold Time	$t_{DH2}$	30	ns	$C_L \leq 80\text{pF}$

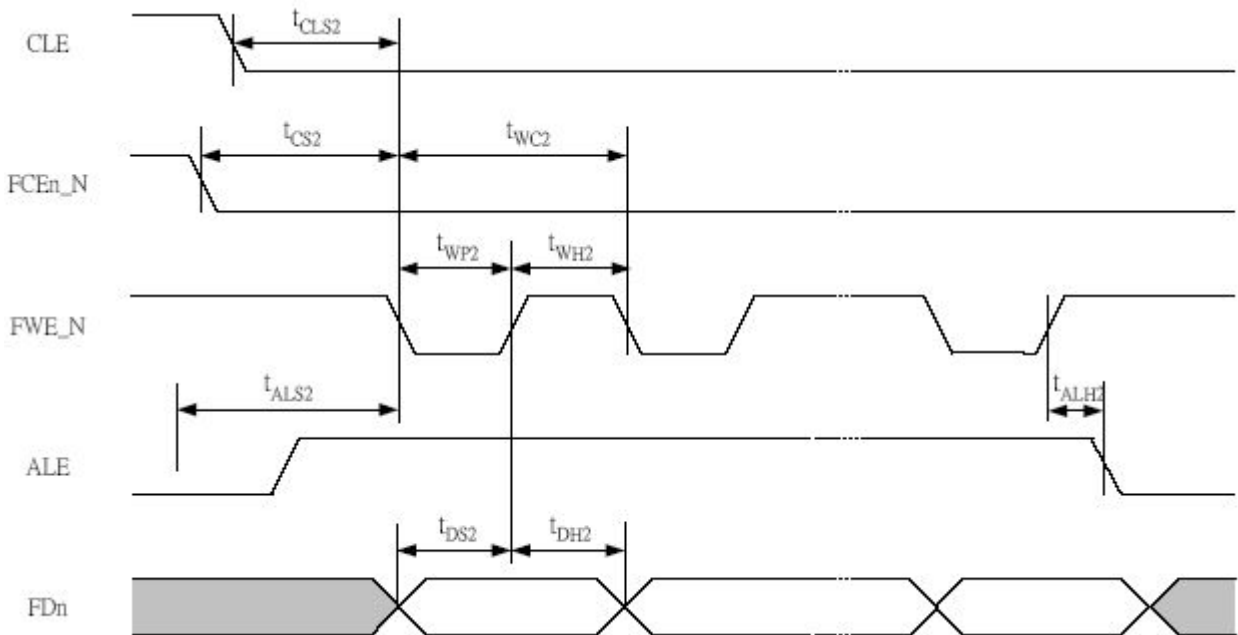

## • Input Data Latch Cycle

Parameter	Symbol	Min.	Unit	Remark
CLE Hold Time	$t_{CLH3}$	285	ns	$C_L \leq 80\text{pF}$
CE Hold Time	$t_{CH3}$	195	ns	$C_L \leq 80\text{pF}$
ALE Setup Time	$t_{ALS3}$	90	ns	$C_L \leq 80\text{pF}$
Write Cycle Time	$t_{WC3}$	60	ns	$C_L \leq 80\text{pF}$
WE Pulse Width	$t_{WP3}$	45	ns	$C_L \leq 80\text{pF}$
WE High Hold Time	$t_{WH3}$	15	ns	$C_L \leq 80\text{pF}$
Data Setup Time	$t_{DS3}$	30	ns	$C_L \leq 80\text{pF}$
Data Hold Time	$t_{DH3}$	30	ns	$C_L \leq 80\text{pF}$

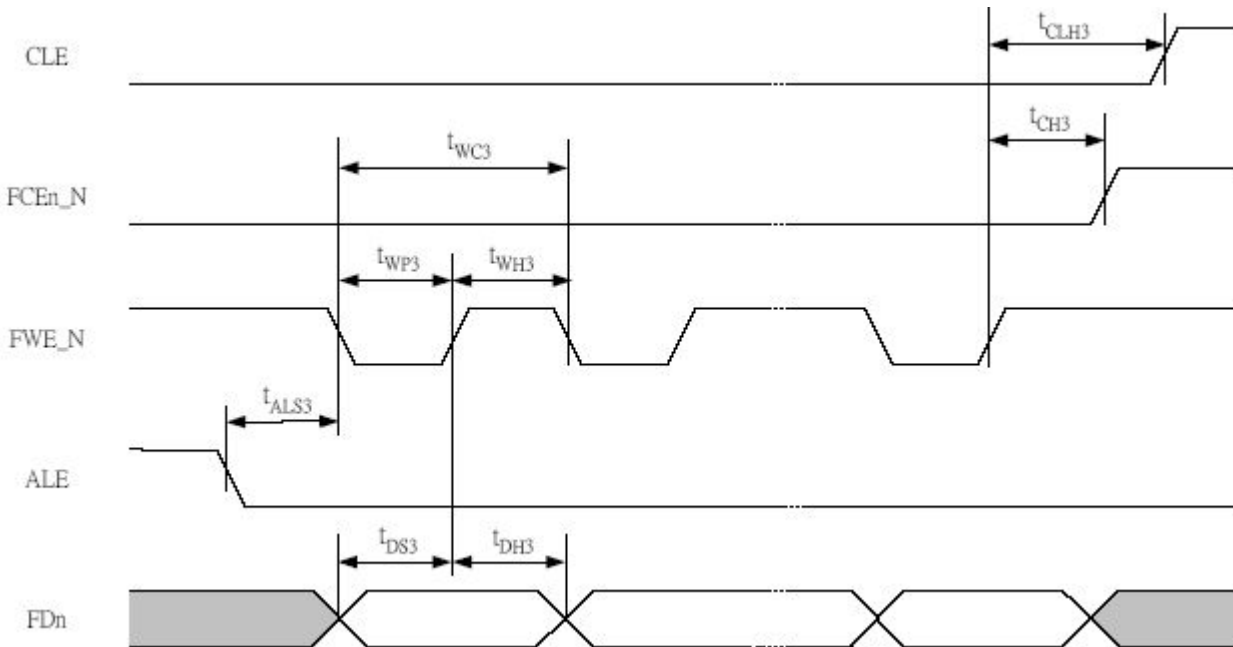

• Serial Access Cycle after Read

Parameter	Symbol	Min.	Unit	Remark
CE Access Time	$t_{CEA4}$	285	ns	$C_L \leq 80\text{pF}$
Read Cycle Time	$t_{RC4}$	60	ns	$C_L \leq 80\text{pF}$
RE Pulse Width	$t_{RP4}$	45	ns	$C_L \leq 80\text{pF}$
RE High Hold Time	$t_{REH4}$	15	ns	$C_L \leq 80\text{pF}$
Data Setup Time	$t_{DS4}$	5(TBD)	ns	$C_L \leq 80\text{pF}$
Data Hold Time	$t_{DH4}$	5(TBD)	ns	$C_L \leq 80\text{pF}$
Ready to RE Low	$t_{RR4}$	285	ns	$C_L \leq 80\text{pF}$

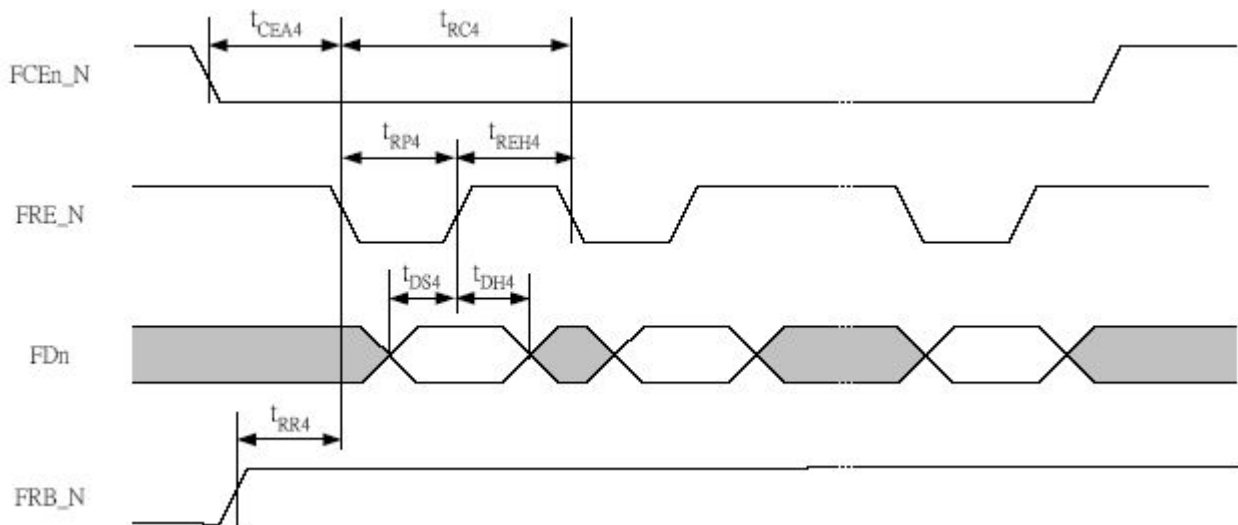

## Reliability and Durability

Temperature	Operation: -25°C / 85°C Storage: -40°C (168h) / 85°C (500h) Junction temperature: max. 95°C
Moisture and corrosion	Operation: 25°C / 95% rel. humidity Stress: 40°C / 93% rel. hum./500h Salt Water Spray: 3% NaCl/35C; 24h acc. MIL STD Method 1009
ESD protection	Contact Pads: +/-4kV, Human body model according to ANSI EOS/ESD-S5.1-1998 Non Contact Pads area: +/-8kV(coupling plane discharge) +/-15kV(air discharge) Human body model according to IEC61000-4-2
Durability	10.000 mating cycles; test procedure: t.b.d.
Bending	t.b.d.
Torque	t.b.d.
Drop test	1.5m free fall
UV light exposure	UV: 200nm, 15Ws/cm <sup>2</sup> according to ISO 7816-1
Visual inspection Shape and form	No warp page; no mold skin; complete form; no cavities surface smoothness sigma -0.1 mm/cm <sup>2</sup> within contour; no cracks; no pollution (fat, oil dust, etc.)

Above technical information is based on MMC4.0 standard specification and tested to be reliable. However, Transcend makes no warranty, either expressed or implied, as to its accuracy and assumes no liability in connection with the use of this product. Transcend reserves the right to make changes in specifications at any time without prior notice.